

## Support Guidelines for Quartz Countertops

The maximum overhang is no more than  $\frac{1}{3}$  of the total dimension of the countertop – not to exceed 15".

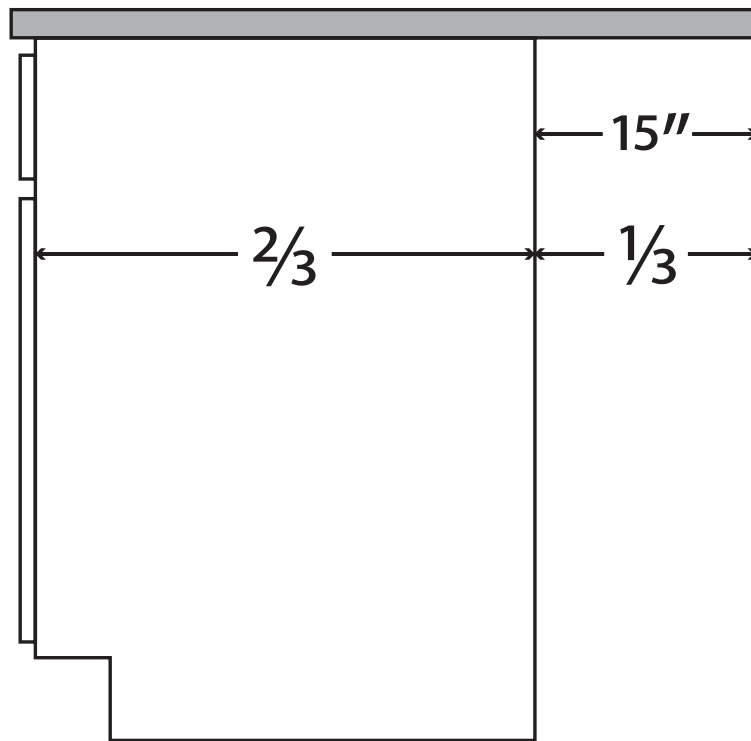

Overhang greater than 15" requires corbels or flush mounted steel supports. Supports must be designed to bear the weight of the countertop and be mounted to studs or equivalent load bearing structure. Supports can bear no more than 24" of overhang. Maximum 36" between centers of each adjacent support.

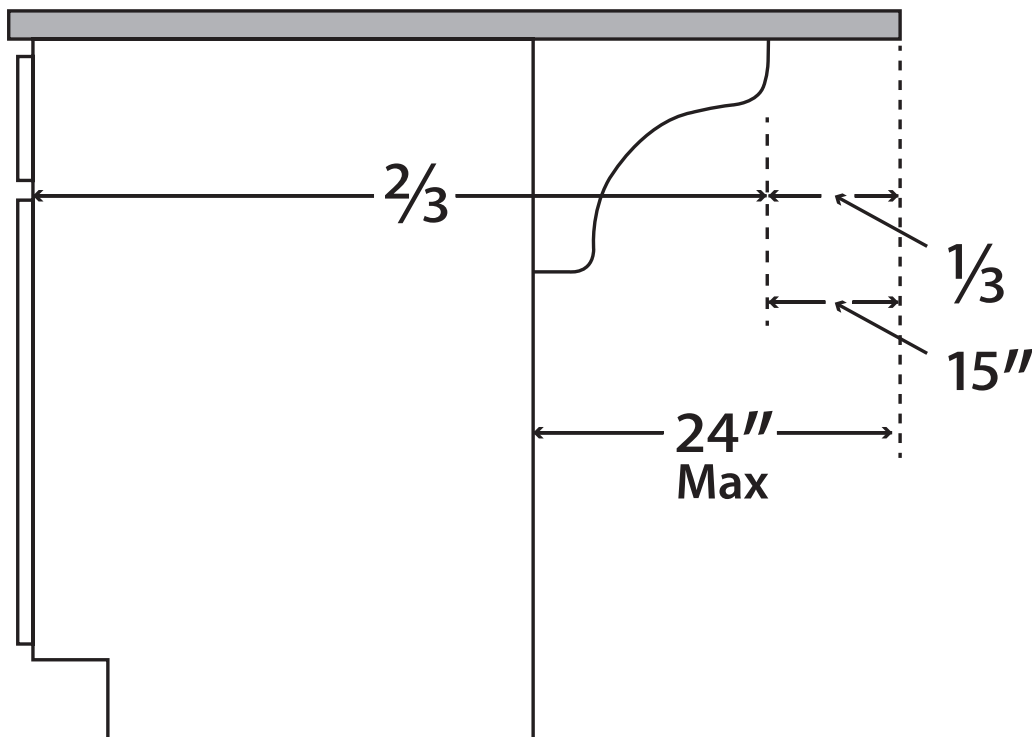

Overhang that exceeds 24" requires the use of substrate and posts installed evenly at a maximum of 36" between centers of each adjacent support.

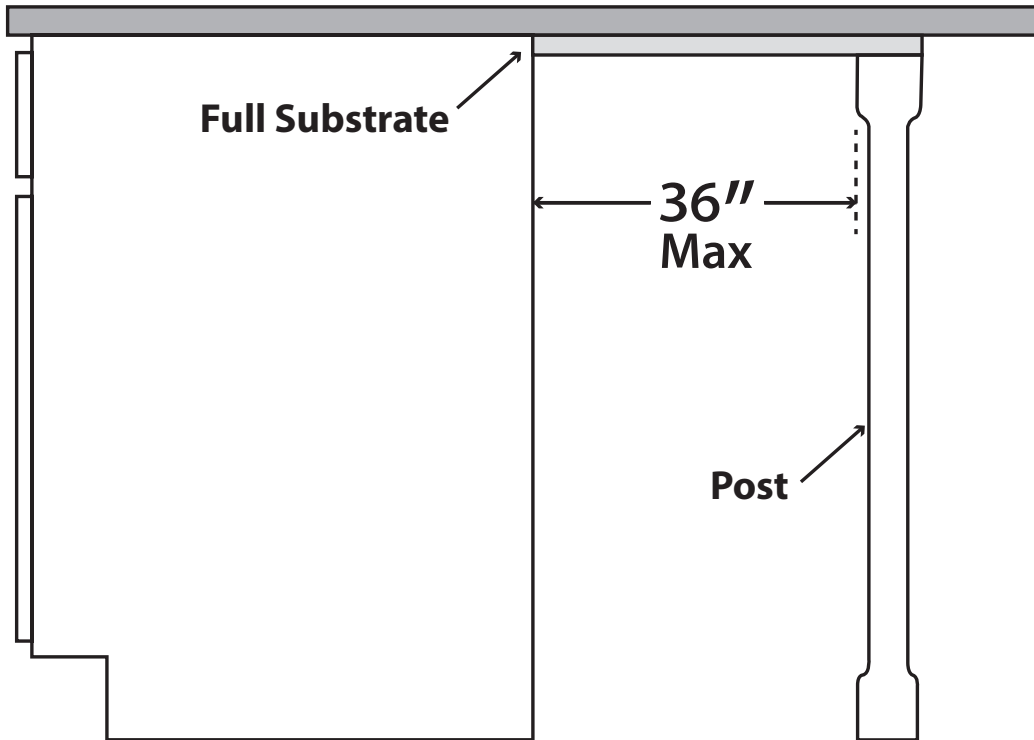

Tops on half wall can be installed using steel supports with overhang up to 12". Overhang greater than 12" will require corbels or legs.

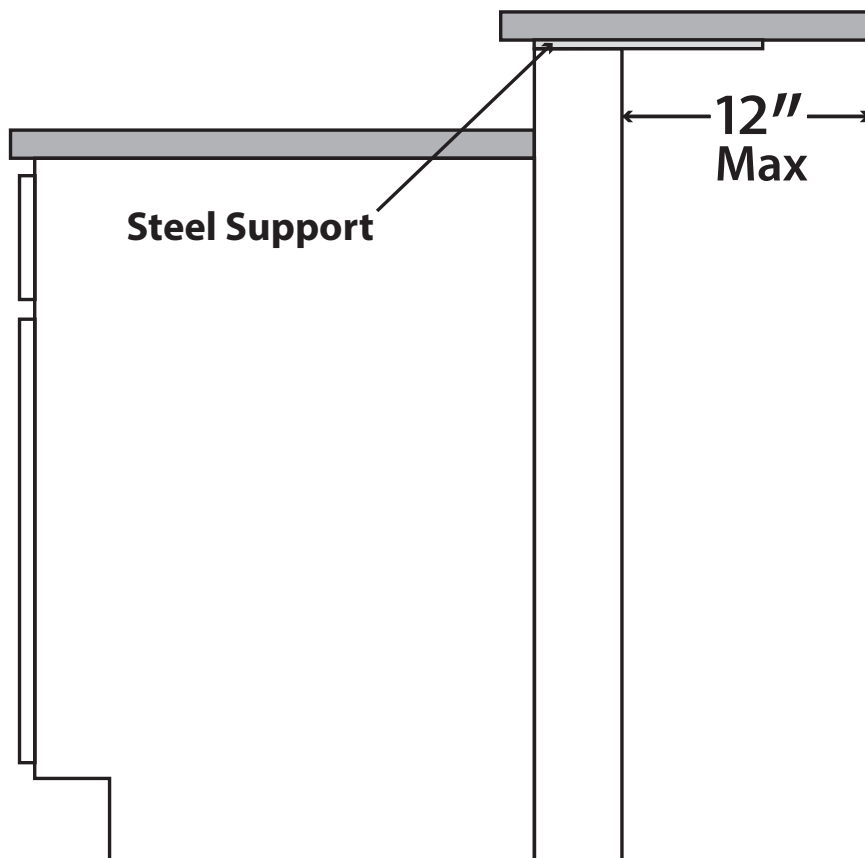

Tabletop application requires the use of a full substrate which extends within 4" of the edge of the table top. The manufacturer's specification for the pedestal must be checked to verify it is designed to support the size and weight of the table top.

